



Enclosed Conductor Rail

Mobile Electrification System

Catalogue

HFP56 - HFP52 - HFP95 Series



General

NANTE HFP Enclosed Conductor Rail System is a compact, reliable and safe current supply system for cranes, hoists, monorail systems, conveyor belts etc.

The basic design of HFP Conductor Rail System is a PVC housing which is prepared to accommodate copper conductors, and current collector run in the PVC housing to get the power and feed it to the equipment. NANTE HFP series Conductor Rail can be 4poles, 7 poles and 10poles with current capacity from 35A to 240A.

System Description

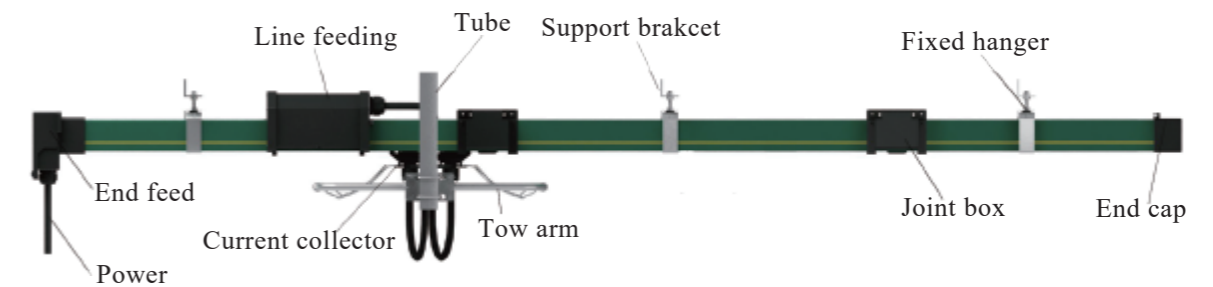

Technical Data

Electrical properties:

Max.current	240A
Max.voltage	660V
Dielectric strength	30-40KV/mm
Spec.resistance	$5 \times 10^5 \text{ Ohm} \times \text{cm}$
Surface resistivity	$10^{13} \text{ Ohm} \times \text{cm}$
Leakage resistance	CTI600-2.7

Combustibility:

Flame retardant	B1 Class
Self extinguishing	Class B1 - no flaming particles, self-extinguishing

Mechanical properties:

Flexible strength	$75 \text{ N/mm}^2 \pm 10\%$
Tensile strength	$40 \text{ N/mm}^2 \pm 10\%$
Temperature range:	
Standard Housing	-20°C up to +70°C
High Temp.Housing	-10°C up to +115°C



Please contact with Nante technical team for special projects and conditions

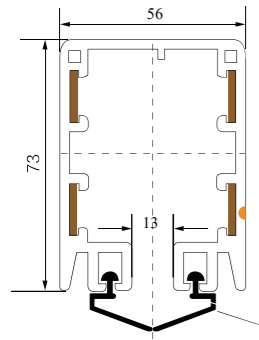

Model Code
HFP56-4-n/m

n: max.current capacity
m: conductor cross section

Standard Length: 4m, others is available,
but not more than 6m

Joint menthod: 50A~120A connected by screw
140A~240A connected by bolted joint

Support Bracket Spacing: 1.2m for straight travel

Sealing strip (be ordered separately)

Sealing strip

Model	Pole No.	Cross section (mm ²)	Max. current (A)	Leakage-distance (mm)	Max. voltage (V)	Resistance (Ω/km)	Weight (kg)
HFP56-4-8/35	4	8	35	35	600	1.944	2.09
HFP56-4-10/50	4	10	50	35	600	1.656	2.16
HFP56-4-12/65	4	12	65	35	600	1.321	2.23
HFP56-4-15/80	4	15	80	35	600	1.137	2.3
HFP56-4-20/100	4	20	100	33	600	1.011	2.43
HFP56-4-25/120	4	25	120	33	600	0.713	2.56
HFP56-4-35/140	4	35	140	33	600	0.522	2.95
HFP56-4-50/170	4	50	170	33	600	0.337	3.25
HFP56-4-70/210	4	70	210	33	600	0.265	3.85
HFP56-4-80/240	4	80	240	30	600	0.223	4.16

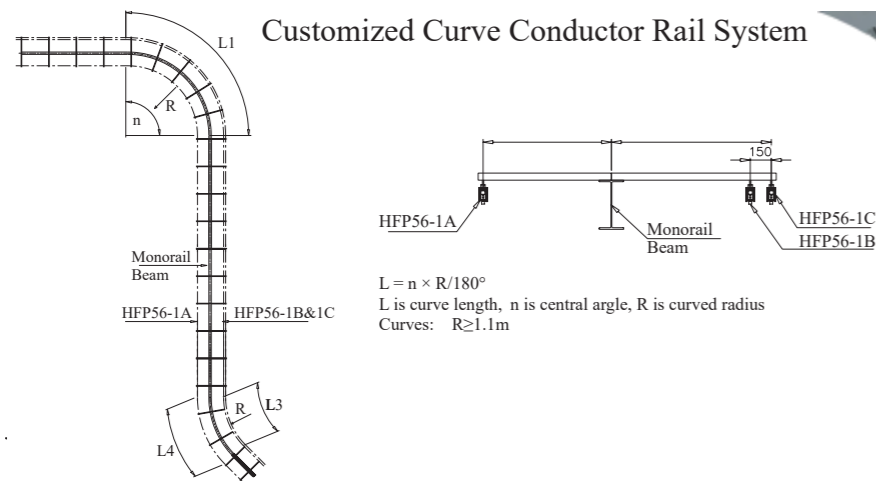

HFP56 Accessories - Current Collector
56JD-40



40A current collector is used for conductor bar 35A -120A

Type	Weight (kg)	Poles	Power rating
56JD-4/40	0.7	4	40A

HFP56 Accessories - Current Collector
56JD-60 / 56JD-80

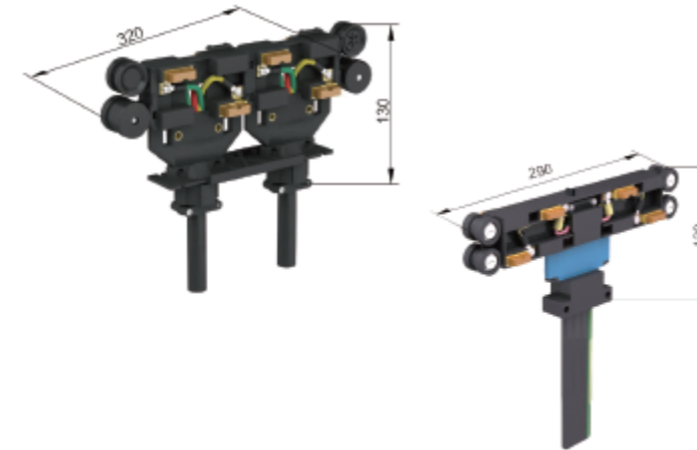

60A current collector is used for conductor bar 120 -170A

Type	Weight (kg)	Poles	Power rating
56JD-4/60	1.35	4	60A

80A current collector is used for conductor bar 140-240A

Type	Weight (kg)	Poles	Power rating
56JD-4/80	1.3	4	80A

HFP56 Accessories - Current Collector
56JDR-25/40 for Curves (R>1100mm)



25A current collector is used for conductor bar 50A

40A current collector is used for conductor bar 65A-120A

Type	Weight (kg)	Poles	Power rating
56JDR-4/25	0.5	4	25A
56JDR-4/40	0.6	4	40A

HFP56 Accessories - Carbon Brush Assembly
56CB-1 / 56CB-2



56TS-1

56TS-2

Type	Weight (kg)	Remark
56CB-1	0.04	Be used for: 56JD series collector
56CB-2	0.04	56JDR series collector

HFP56 Accessories - Jointing Box
56JBX/45 for bended joints (conductor rail ≤120A)

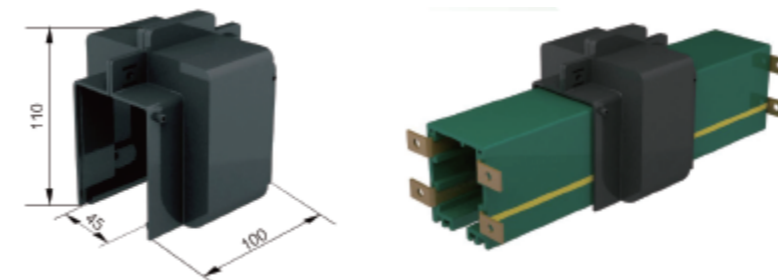

Type	Weight (kg)	Material
56JBX/45	0.09	Plastic

HFP56 Accessories - Jointing Box
56JBX-5 for bolted joints (conductor rail $\geq 140A$)

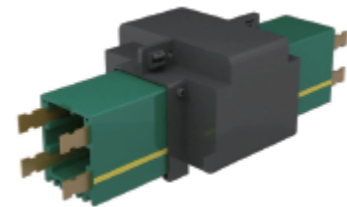
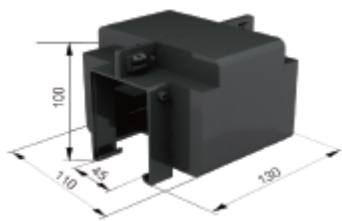

Type	Weight (kg)	Material
56JBX-5	0.16	Plastic

HFP56 Accessories - Fixed Hanger
56HG-3

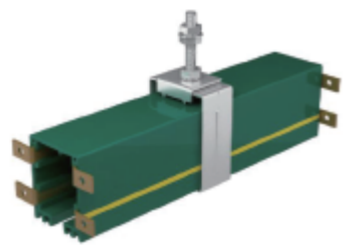
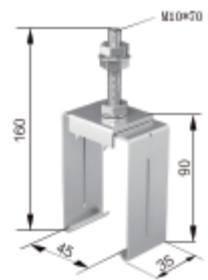

Type	Weight (kg)	Material
56HG-3	0.21	Steel

Special note: Max.2pcs each traveling line

HFP56 Accessories - Sliding Hanger
56HG-4

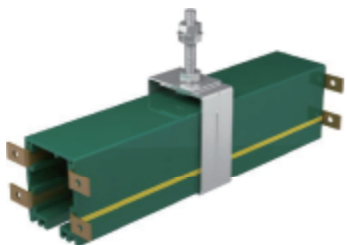
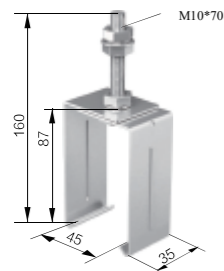

Type	Weight (kg)	Material
56HG-4	0.17	Steel

HFP56 Accessories - Bolted Joint
56BT

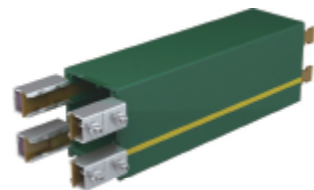

Type	Weight (kg)	Material
56BT-80A	0.042	Steel cover & Copper plate
56BT-120A	0.049	
56BT-140A	0.053	
56BT-240A	0.085	

HFP56 Accessories - End Feed / End Feeding Joint
56EF / 56EJ

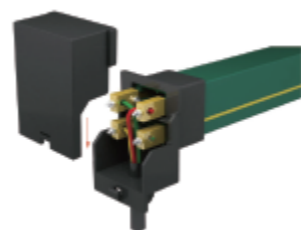
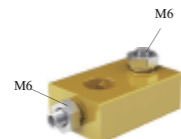
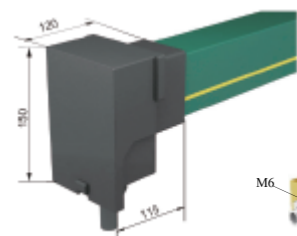

Type	Weight (kg)	Material
56EF	0.25	Plastic
56EJ	0.06	Brass

HFP56 Accessories - End Cap
56EC

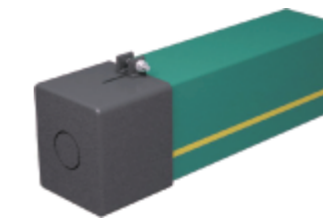
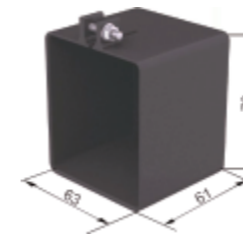

Type	Weight (kg)	Material
56EC	0.065	Plastic

HFP56 Accessories - Line Feed (with 0.5meter powerail)
56LF/500-X/m

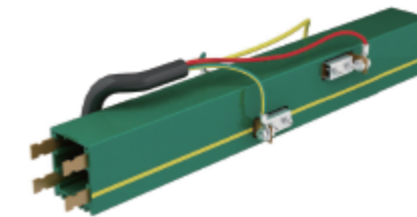
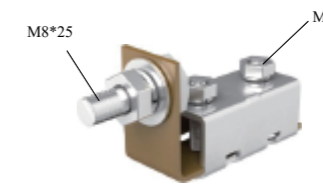
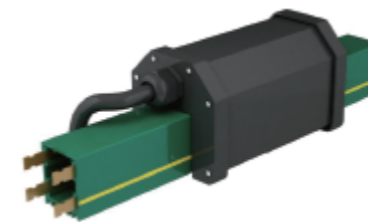

Type	Weight (kg)
56LF/500-4/80	1.91
56LF/500-4/120	2.07
56LF/500-4/140	2.18
56LF/1000-4/240	5.14

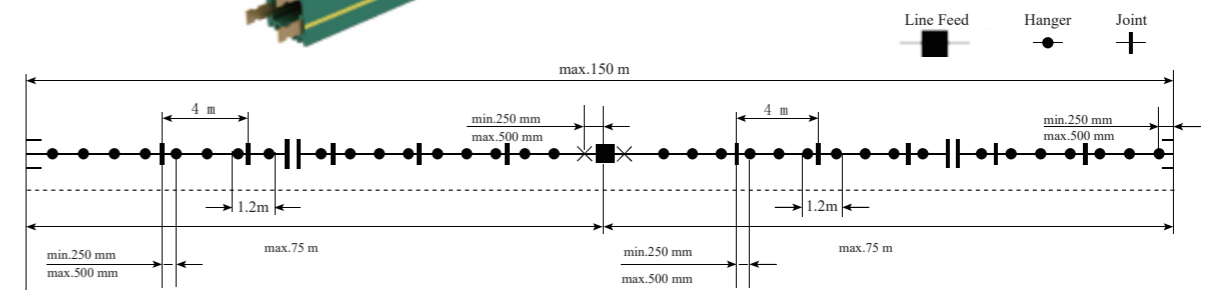

HFP56 Accessories - Conductor Isolating Section
56IS

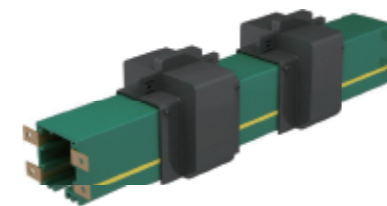

Type	Material
56IS	Plastic with copper

HFP56 Accessories - Tow Arm
56TM/53

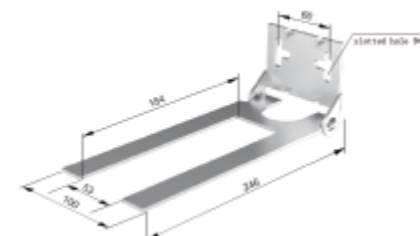

Type	Weight (kg)	Material
56TM/53	0.53	Steel

HFP56 Accessories - Led Light
56LED



Type	Weight kg	Material
56LED	0.28	Plastic

HFP56 Accessories - Sealing Strip
56SLT

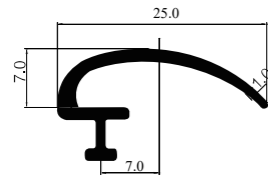

Type	Weight kg	Material
56SLT	0.065	Plastic

sealing strip is used for dusty or fireproof ambient, usually 50meters in one packing

Symbols

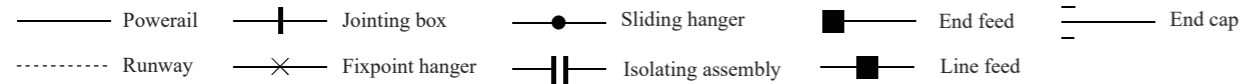

Each sliding hanger can be converted to a fixpoint hanger.

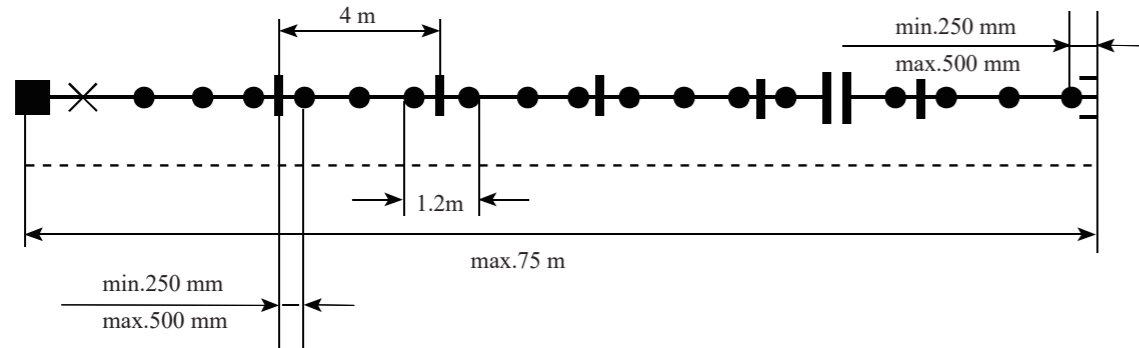

Maintenance Guide

- 1) After installation, Make sure that the sliding hangers are straight (in a perpendicular position) after nuts have been tightened to guarantee free sliding of the power rail. The power rail must be installed exactly straight and parallel to the machinery track.
- 2) Before running the power rail. Check the system for easy running of the current collector trolleys. i.e. there may be no resistance by an excessively narrow slot or pull by the connecting cable.
- 3) Every 3 up to max. 12 months, depending on the frequency of operation and travel distance, check the carbon brushes and mechanical components for wear and replace them if necessary.
- 4) There is no more than 2 pcs fixed hanger in one traveling line
- 5) Line feed is fixed for the long traveling line which is more than 75 meters

Installed on C-Track Bracket (for split)

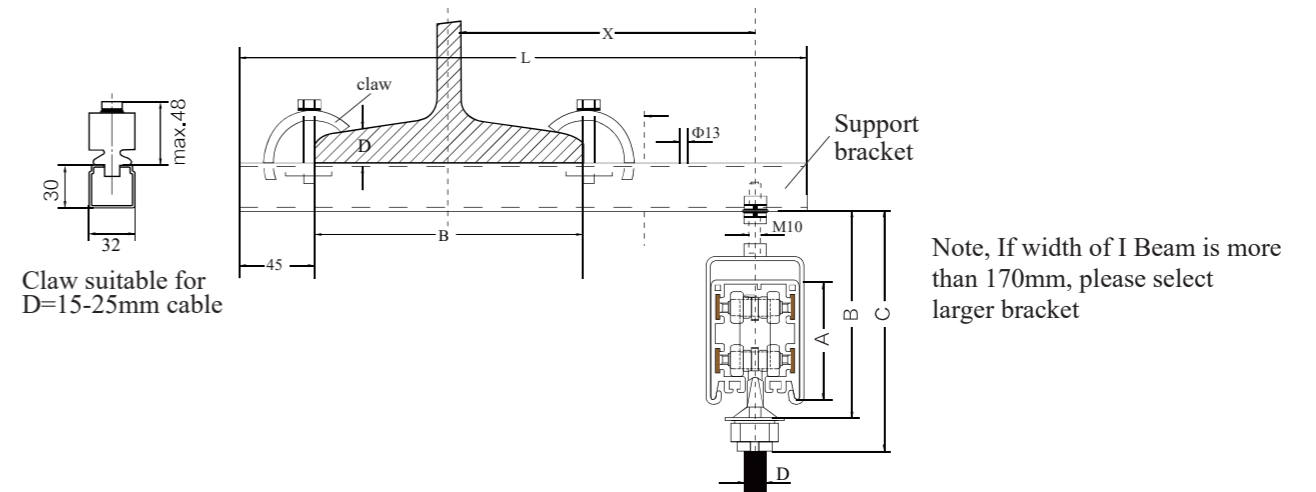
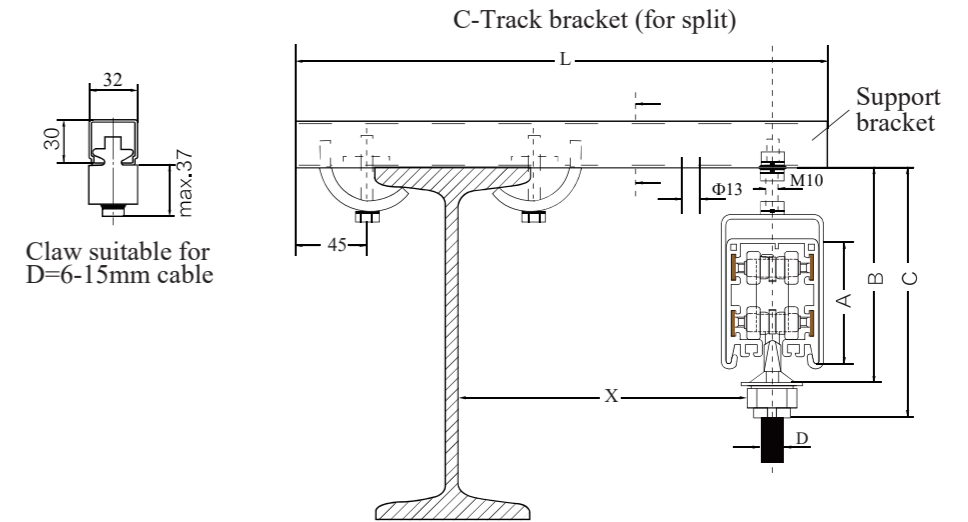

Installed on Angle Steel Bracket (for welding)

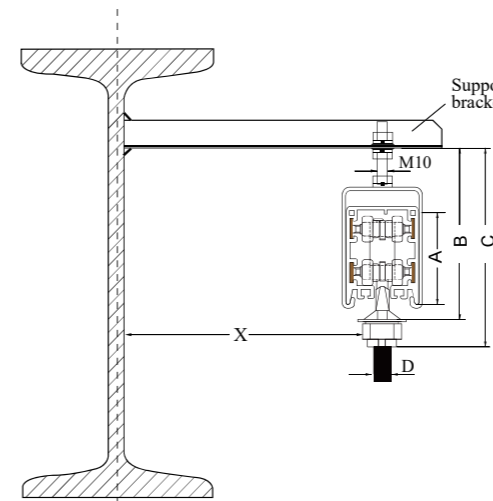

Installed on C-Track Bracket (for welding)

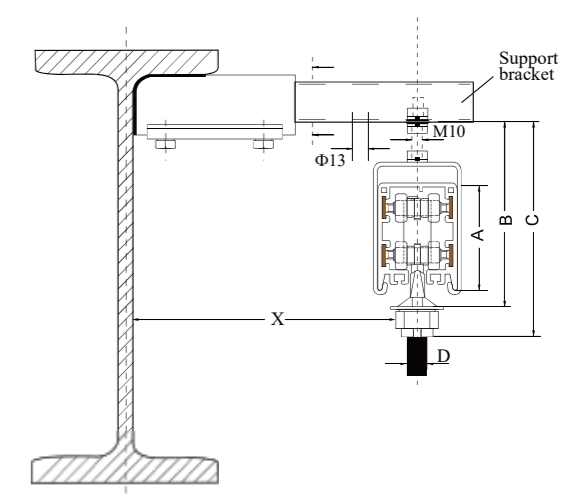

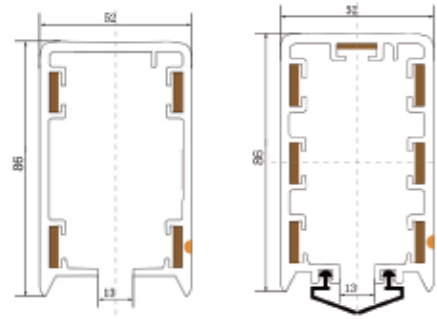

Model Code
HFP52-4/7-n/m

n: max.current capacity
m: conductor cross section

Standard Length : 4m, others is available,
but not more than 6m

Curves: $R \geq 1.1m$, 7poles without curve

Joint method: Connected by bolted joint

Support Bracket : 1pc/1.2m for straight travel

Sealing strip (To be ordered separately)

Model	Pole No.	Cross section (mm ²)	Max. current (A)	Leakage-distance (mm)	Max. voltage (V)	Resistance (Ω)	Weight (kg)
HFP52-4-10/50	4	10	50	55	600	1.656	2.05
HFP52-7-10/50	7	10	50	15	600	1.656	2.32
HFP52-4-15/80	4	15	80	55	600	1.137	2.32
HFP52-7-15/80	7	15	80	15	600	1.137	2.71
HFP52-4-20/100	4	20	100	55	600	1.011	2.47
HFP52-7-20/100	7	20	100	15	600	1.011	2.99
HFP52-4-25/120	4	25	120	55	600	0.713	2.63
HFP52-7-25/120	7	25	120	15	600	0.713	3.27
HFP52-4-35/140	4	35	140	55	600	0.522	2.97
HFP52-7-35/140	7	35	140	15	600	0.522	3.87

HFP52 Accessories - Current Collector
52JD-4/40 52JD-7/40

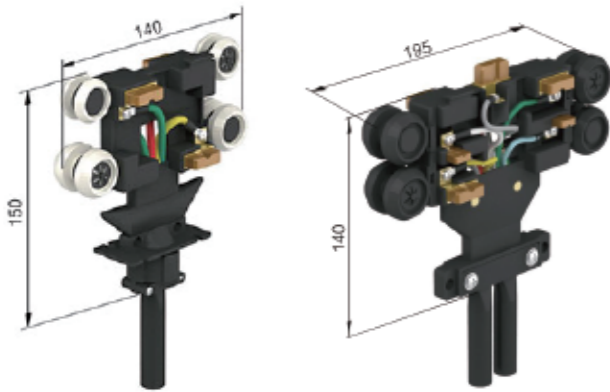

40A current collector is used for conductor bar 50A-120A

Type	Weight (kg)	Poles	Power rating
52JD-4/40	0.61	4	40A
52JD-7/40	1.07	7	40A

HFP52 Accessories - Carbon Brush
52CB-1 52CB-2



Type	Weight (kg)	Remark
52CB-1	0.03	Be used for: 52JD-4/40 52JD-7/40
52CB-2	0.03	52JD-7/40

HFP52 Accessories - Jointing Box
52JBX-1 52JBX-2

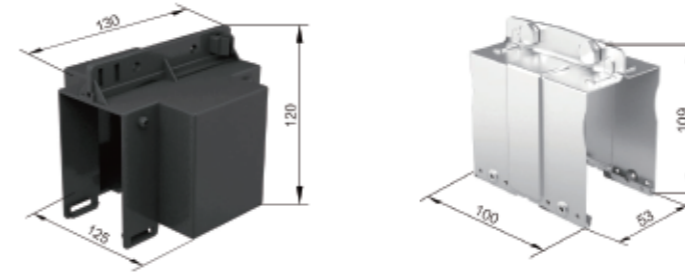

Type	Weight (kg)	Material
52JBX-1	0.22	Plastic
52JBX-2	0.26	Steel

HFP52 Accessories - Hanger
52HG-1 52HG-2



Type	Weight (kg)	Material
56HG-1	0.21	Steel
56HG-2	0.17	Steel

Note: 56HG-1 is fixed hanger,
No more 2pcs for each traveling line

HFP52 Accessories - Line Feed
52LF/500-X/m

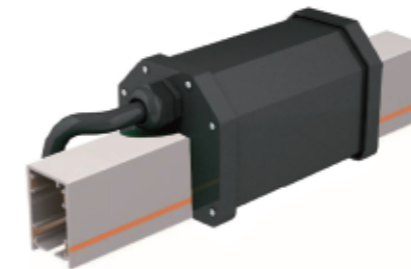

Type	Weight (kg)
52LF/500-4/80A	1.77
52LF/500-4/140A	2.02
52LF/500-7/80A	3.05
52LF/500-7/140A	3.50

Note: Lind feed is required for the line more than 75m

HFP52 Accessories - Bolted Joint
52BJ



Type	Weight (kg)	Material
52BJ-80A	0.041	Steel cover & Copper plate
52BJ-120A	0.048	
52BJ-140A	0.052	
52PBT-50A	0.031	Steel cover & Copper plate
52PBT-80A	0.038	
52PBT-100A	0.052	

HFP52 Accessories - End Cap
52EC

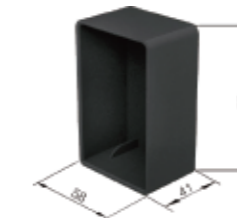

Type	Weight (kg)	Material
52EC	0.05	Plastic

HFP52 Accessories - End Feed
52EF



Type	Weight (kg)	Material
52EF	0.22	Plastic

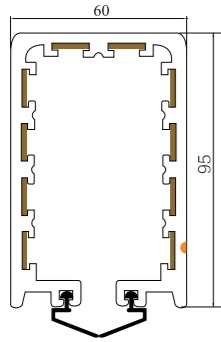

Model Code
HFP95-p-n/m

p: 5, 6, 7, 8, 9, 10

n: max.current capacity

m: conductor cross section

Standard Length : 4m, others is available,
but not more than 6m

Curves: $R \geq 1.5m$, 9pole and 10pole without curves

Joint method: No joints or by screws

Support Bracket : 1pc/1.2m for straight travel

Sealing strip (To be ordered separately)

Model	Pole No.	Cross section (mm ²)	Max. current (A)	Leakage-distance (mm)	Max. voltage (V)	Resistance (Ω)	Weight (kg)
HFP95-5-10/50	10	10	50	20	660	1.656	3.2
HFP95-5-15/80	10	15	80	20	660	1.193	3.28
HFP95-5-20/100	10	20	100	20	660	1.011	3.51
HFP95-6-10/50	10	10	50	20	660	1.656	3.16
HFP95-6-15/80	10	15	80	20	660	1.193	3.41
HFP95-6-20/100	10	20	100	20	660	1.011	3.68
HFP95-7-10/50	10	10	50	20	660	1.656	3.25
HFP95-7-15/80	10	15	80	20	660	1.193	3.56
HFP95-7-20/100	10	20	100	20	660	1.011	3.88
HFP95-8-10/50	10	10	50	20	660	1.656	3.34
HFP95-8-15/80	10	15	80	20	660	1.193	3.7
HFP95-8-20/100	10	20	100	20	660	1.011	4.04
HFP95-9-10/50	10	10	50	20	660	1.656	3.42
HFP95-9-15/80	10	15	80	20	660	1.193	3.77
HFP95-9-20/100	10	20	100	20	660	1.011	4.24
HFP95-10-10/50	10	10	50	20	660	1.656	3.54
HFP95-10-15/80	10	15	80	20	660	1.193	3.98
HFP95-10-20/100	10	20	100	20	660	1.011	5.21

HFP95 Accessories - Current Collector
95JD

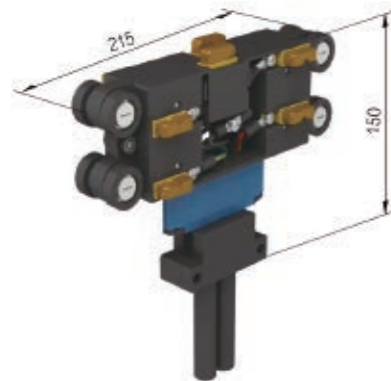

25A current collector is used for conductor bar 50A
40A current collector is used for conductor bar 65A-100A

Type	Weight (kg)	Poles	Power rating
95JD-5/25	1.05	5	25A
95JD-5/40	1.13	5	40A
95JD-8/25	1.25	8	25A
95JD-8/40	1.35	8	40A
95JD-10/25	1.45	10	25A
95JD-10/40	1.60	10	40A

HFP95 Accessories - Current Collector
95JDR

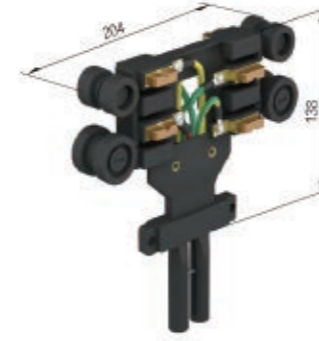

25A current collector is used for conductor bar 50A
40A current collector is used for conductor bar 65A-100A

Type	Weight (kg)	Poles	Power rating
95JDR-5/25	0.85	5	25A
95JDR-5/40	0.89	5	40A
95JDR-6/25	0.94	6	25A
95JDR-6/40	0.99	6	40A
95JDR-8/25	1.22	8	25A
95JDR-8/40	1.32	8	40A

HFP95 Accessories - Jointing Box
95JBX

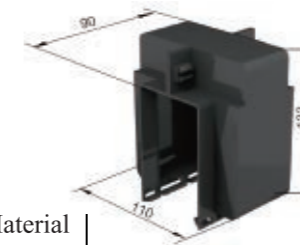

Type	Weight (kg)	Material
95JBX	0.11	Plastic

HFP95 Accessories - Line Feed
95LF



Type
95LF

HFP95 Accessories - Hanger
95HG-1 95HG-2

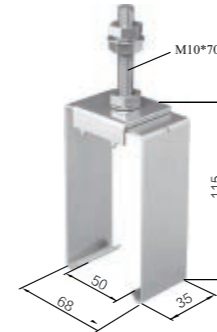

Type	Weight (kg)	Material
95HG-1	0.26	Steel
95HG-2	0.23	Steel

Special note: Max.2pcs each traveling line

HFP95 Accessories - Carbon Brush
95CB



Type	Weight (kg)	Remark
95CB	0.04	Be used for: 95JD and 95JDR

HFP95 Accessories - End Cap
95EC

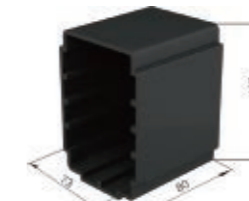

Type	Weight (kg)	Material
95EC	0.1	Plastic

HFP95 Accessories - End Feeding
95EF

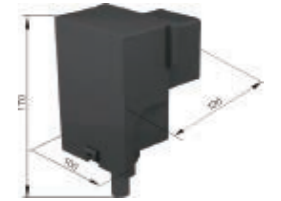

Type	Weight (kg)	Material
95EF	0.28	Plastic